

A critical review of 3D concrete printing as a low CO₂ concrete approach

Yu Chen ¹, Fred Veer ², Oguzhan Çopuroğlu ¹

¹ Faculty of Civil Engineering and Geosciences, Delft University of Technology, the Netherlands

² Faculty of Architecture and the Built Environment, Delft University of Technology, the Netherlands

Concrete is by volume the most widely used building material all over the world. The concrete industry emits large quantities of greenhouse gases. Therefore, developing low CO₂ concrete becomes an urgent issue for those countries with significant concrete production and consumption. In recent years, 3D concrete printing (3DCP) which is a new concrete construction method, is being developed by many research institutions and enterprises throughout the world. The primary advantages of 3DCP include increasing architecture flexibility, reducing labor usage, as well as saving in-situ construction time and cost. According to the statements by Tay et al. [2017], Wolfs et al. [2018], and Bos et al. [2016], 3DCP as a future construction trend may be a potential low CO₂ approach. Thus, the objective of this paper is to critically explore the possible low CO₂ strategies for 3DCP which have not been systematically conducted so far. Initially, this study introduces an overview of 3DCP by reviewing the relevant publications over last 20 years. Moreover, the potential low CO₂ aspects of 3DCP are illustrated and discussed. Finally, the challenges and opportunities of developing 3DCP are analyzed and summarized. Overall, 3DCP is exploring possibilities of a low CO₂ concrete approach, since it might consume less concrete materials and does not need formwork. On the other hand, to maximize CO₂ reduction and accelerate the development of this technique, the future routes of 3DCP can be identified such as developing low CO₂ printable concrete, seeking the proper reinforcement methods, improving print quality and capability.

Keywords: 3D concrete printing, low CO₂, printable concrete, reinforcement, print quality and capability

1 Background and introduction

Concrete is volumetrically the most important and widely used human-made construction material throughout the world. There are many advantages to using concrete for the construction of buildings and other types of structures. First, concrete is typically preferred for its low cost, good strength, exceptional durability, as well as excellent fire resistance [Gursel and Ostertag, 2017, Meyer, 2009, Mehta and Monteiro, 2006]. The second reason is that the raw materials for concrete can be obtained practically anywhere in the world. Furthermore, concrete is also a flexible material giving considerable design freedom to architects [Glavind, 2009]. The world consumption of concrete is close to 25 gigatons each year. So, it means that more than 3.8 tons of concrete is used globally per person each single year [Gursel et al., 2014]. The massive production and consumption of concrete generates a substantial burden on our living environment. The manufacturing processes of Portland cement consume large quantities of energy and emit massive amounts of greenhouse gases [Meyer, 2009]. According to the report from Dong et al. [2015], the cement industry is currently responsible for 5-7% of the global total CO₂ emissions. As a primary construction material, concrete will continue to be in demand far into the future [Imbabi et al., 2012]. It is necessary to improve the sustainability of concrete structures to make sure that concrete will still be a competitive construction material [Proske et al., 2013]. Additionally, labor safety is an increasing concern for in-situ concrete manufacturing. Skilled labor is required in the processes of placing and connecting the reinforcement, and erecting the formwork, especially for casting customized geometries [Bos et al., 2016]. The workers are continuously threatened by work-related injuries and illnesses [Tay et al., 2017, Kittusamy and Buchholz, 2004].

Additive manufacturing of concrete (AMoC) seems one solution to address the challenges of current concrete industry described above. According to the ASTM [2013], additive manufacturing (AM) is defined as: “a process of joining materials to make objects from 3D model data, usually layer upon layer, as opposed to subtractive manufacturing methodologies”. During the past three decades, AM has been commercially used in aerospace, medical applications, and other fields [Evans and Ian Campbell, 2003]. In the construction area, contour crafting, D-shape, and concrete printing as recent implementations show the potential of using AM techniques as large-scale fabrication methods [Lim et al., 2016]. Contour crafting and concrete printing are the major approaches of AMoC which is also named 3DCP in this paper. 3DCP can be defined as a

fabrication method that employs an additive, layer-based manufacturing technique to make concrete components without formwork [Malaeb et al., 2015, Buswell et al., 2007, Lim et al., 2009]. In contrast to the conventional method of concrete construction, 3DCP shows massive advantages. The primary benefit is that using 3DCP could save 35% to 60% of the total monetary expense of concrete construction since no formwork is needed [Shakor et al., 2017, Lloret et al., 2015]. Without formwork in concrete printing, less construction time and labor are required. The workforce will be shifted to a more skilled and technology-oriented workforce. Incidents of fatalities and injuries should thus be significantly reduced [Biernacki et al., 2017]. Additionally, 3DCP is a sustainable construction approach with decreased environmental impact. It is expected to reduce construction waste by the accurately controlled manufacturing process and optimized material consumption [Biernacki et al., 2017, Oxman et al. 2014]. Moreover, according to the statements by Tay et al. [2017], Wolfs et al. [2018], and Bos et al. [2016], 3DCP as a future construction trend may potentially be a low CO₂ approach to concrete manufacturing.

This paper aims to critically explore the potential low CO₂ properties and developing feasibilities of 3DCP which have not been systematically explored so far. Thus, this study initially introduces an overview of the work on 3DCP in different research institutes by reviewing the relevant publications over the last 20 years. Additionally, the potential low CO₂ aspects of 3DCP are illustrated and discussed. Finally, the challenges and opportunities of developing low CO₂ 3DCP were analyzed and summarized.

2 Overview of 3D concrete printing

3D printing for large-scale construction is based on two printing techniques, namely extrusion-based printing and powder-based printing [Nematollahi et al., 2017]. Contour crafting and concrete printing is based on the theory of Fused Deposition Modelling belonging to the extrusion-based method, whereas D-shape as an example of a powder-based technique follows a different principle like Stereo-Lithography [Bos et al., 2016]. As shown in Table 1, the manufacturing processes and material types of contour crafting, concrete printing, and 3DCP are quite similar. In this paper, D-shape will not be discussed because of its unique powder and binder fabricating process. Significant studies at present about 3DCP are selected and classified in Figure 1. Through literature review, two fundamental parts of the 3DCP namely concrete printing system and printable materials are summarized.

Table 1: Comparative study of construction-scale additive manufacturing methods

Based on: Bos et al. [2016], Bos et al. [2018], Lim et al. [2012], Perkins and Skitmore [2015], Gosselin et al. [2016], Nematollahi et al. [2017].

Type	Contour crafting	Concrete printing	D-shape	3DCP
Researcher	University of Southern California, USA	Loughborough University, UK	Enrico Dini, Italy	Eindhoven University of Technology, the Netherlands
Starting time	Mid-1990s	2011-2012	2006	September 2015
Printing machine	Robotic / Gantry-based	Gantry-based	Gantry-based	Gantry-based
Use of trowels	Yes	No	No	No
Printable material	Cementitious material; Mortar mixture; Printable clay	Printable concrete	Sand/Stone powder; Chlorine-based liquid as the binding material	Printable concrete mortar
Reinforcement	Yes	Yes	No	Yes
Printing process	Extrusion	Extrusion	3D printing	Extrusion
Nozzle dimension	Circular Ø 9-20 mm	Circular Ø 9-20 mm	Circular Ø 0.15 mm	Rectangular section 40×10 mm
Nozzle number	1	1	6300	1

Layer thickness	13 mm	6 - 25 mm	4 - 6 mm	10 mm
Construction location	On-site	Off-site	Off-site	Off-site
Printing scale	Large scale	Limited scale	Limited scale	Limited scale
Advantages	Smooth surface by trowelling	1. High strengths and better performance concrete 2. Minimum printing process	1. High strengths 2. The remaining sand can be readily reused	Allowing interruption of the flow of filament
Disadvantages	1. Extra process (molding) 2. Weak bonding between batches due to segmented backfilling batches by a one-hour interval 3. Limited to vertical extrusion (yielding 2.5D topologies)	1. Limited printing dimension due to printer frame: 5.4m (L)×4.4m (W)×5.4m (H) 2. Less efficient	1. Slow process 2. Rough surface 3. Limited printing dimension due to printing frame 4. Massive material placement; 5. Removal of unused material	1. Buildability of material is limited 2. The filament consistency in a print session can be changed 3. Limited printing dimension due to printing frame: 9m (L)× 4.5m (W)×2.8m (H)

3D Concrete Printing

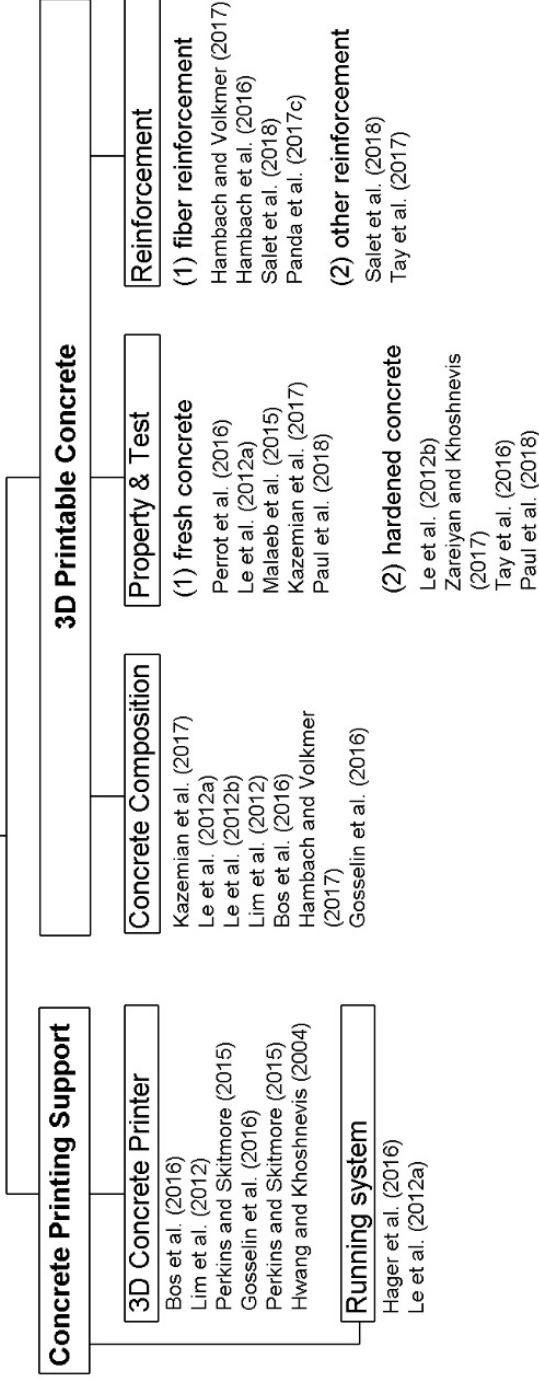
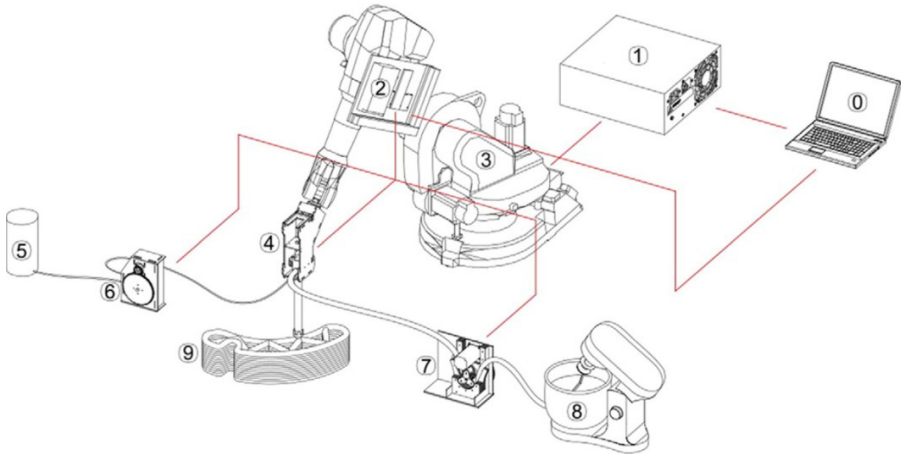

Figure 1: The main literature of 3DCP

2.1 Concrete printing systems

The primary elements of the 3DCP system consist of the hardware and the running system. The 3D printer is the central hardware of the whole system. As shown in Table 1, the printing machine can be classified as a robotic-based or gantry-based printer (Figure 2). A 6-axis robotic arm printer was introduced by Gosselin et al. [2016]. The printer head is connected with two peristaltic pumps (one for the premixed mixture and another for an accelerating agent) which are mounted on an industrial ABB 6620 6-axis robotic arm. An Arduino Mega 2560 microcontroller is used to control the printer head and pumps. The gantry-based printer is entirely different from the robotic-based printer, for example, the 3D printer in the 3DCP research group of Eindhoven University of Technology (TU Eindhoven), the Netherlands. The hose which is linked with the mixer pump is connected to a printer head. The printer head is fixed on a vertical arm that is controlled by a four degree-of-freedom gantry system. A steel nozzle is the end part of the printer head [Bos et al., 2016]. According to Table 1, the shape (round or rectangular) and dimension of the nozzle vary in different concrete printing approaches. In contour crafting, two trowels are used to get the extraordinary smooth and accurate printed surface, which is a major difference with other concrete printing methods [Perkins and Skitmore, 2015]. The detailed design of the nozzle in contour crafting is presented by Hwang and Khoshnevis [2004]. As shown in Table 1, another difference between contour crafting and other concrete printing approaches is the concrete construction place. The construction usually takes place on-site using contour crafting [Hager et al., 2016]. Whereas for other concrete printing methods, the concrete units are printed off-site and assembled on-site.

The running system or workflow is also an essential support for 3DCP. There are three main stages of concrete printing, including data preparation, concrete preparation, and component printing (Figure 3). In the step of data preparation, a 3D CAD model is initially designed, and then converted to an STL file as well as sliced with a certain layer height. The printing paths for those layers is finally converted to a G-Code file for printing [Le et al., 2012a, Paul et al., 2018, Panda et al., 2017a]. Besides, parameters including pump pressure, printing speed, and nozzle standoff distance also play essential roles in the running system. Excellent cooperation between these settings and the properties of the printable material, like extrudability and printability window, are the basis of a successful printing process.



0. System command; 1. Robot controller; 2. Printing controller; 3. Robotic arm;
 4. Print head; 5. Accelerating agent; 6. Peristaltic pump for accelerating agent;
 7. Peristaltic pump for premix; 8. Premix mixer; 9. 3D printed object

Figure 2a: Robotic-based concrete printer, source: Gosselin et al. [2016]

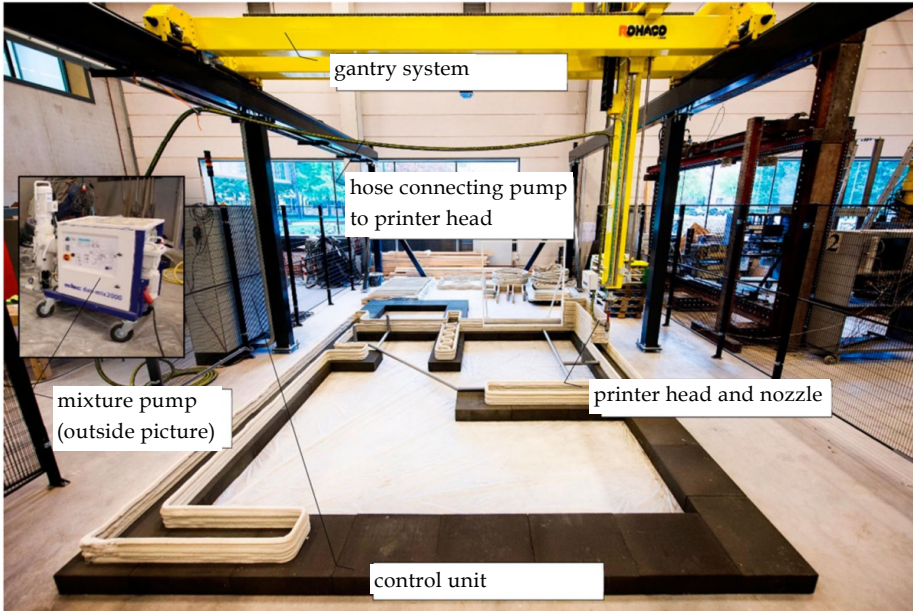

Figure 2b: Gantry-based concrete printer, source: Bos et al. [2016]

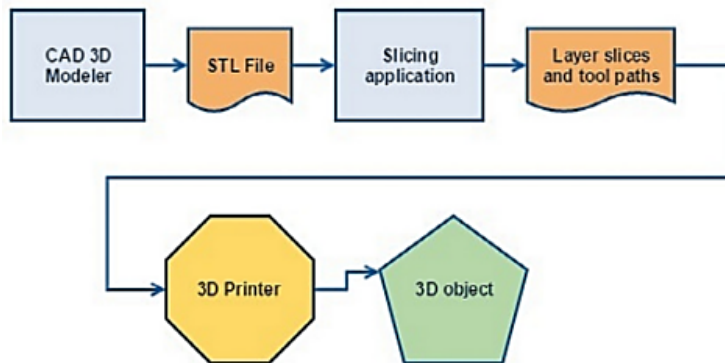

Figure 3: The typical running system of 3D printing, source: Hager et al. [2016]

2.2 Printable materials

The first trial of using a cement-based material in the AM process was performed by Pegna [1997]. During the past 20 years, cement-based material for 3DCP has evolved substantially. Printable concrete combines the features of self-compacting concrete (no need for vibration) and sprayed concrete (concrete expelled through a nozzle) to reach the aim of freeform construction [Le et al., 2012a]. Therefore, a conventional concrete mix design is not valid in 3DCP. However, printable concrete is currently still in the developing stage. There are no standard protocols for the composition of printable concrete [Panda et al., 2017b]. In the overview presented in Table 2, the exploration of printable concrete mixes is based on the investigations by research groups worldwide. Although printable concrete mix designs stem from different research institutes, the main types of constituents (cement, aggregate, water, admixture, and fiber-reinforcement) are similar.

- As shown in Table 2, CEM I Portland cement makes up the highest proportion of the binder content. Supplementary cementitious materials (SCMs) like fly ash, silica fume, and limestone filler are being used to replace up to about 40% of Portland cement. Compared with the conventional high-strength concrete (cement content: 471-495 kg/m³. 28 days compressive strength: at least 100 MPa [Mehta and Monteiro, 2006]), the cement content in 3D printable concrete (540-579 kg/m³ in Table 2, except Nerella et al. [2016]'s) is much higher. Thus, to manufacture 1 m³ of concrete, it will consume more Portland cement by using 3DCP.

Table 2: Overview of the composition of printable concrete at different research institutes

Literature referred	Research institute/ enterprise	Binder type, content	Water content, w/b	Admixture type, content (%w of binder)	Aggregate D_{max} and content	Fiber reinforcement
Kazemian et al. [2017]	University of Southern California	ASTM C150 Type II Portland cement 90%w silica fume 10%w 600 kg/m ³	259 kg/m ³ 0.43	Superplasticizer 0.16	Sand 2.36 mm 1357 kg/m ³	No information available
Le et al. [2012a]	Loughborough University	CEM I 52.5 Portland cement 70%w fly ash 20%w silica fume 10% w 827 kg/m ³	216 kg/m ³ 0.26	Retarder 0.5. superplasticizer 1.0	Sand 2 mm 1241 kg/m ³	Polypropylene microfibers (12/0.18 mm)
Bos et al. [2016]	Eindhoven University of Technology	CEM I 52.5 R Portland cement, limestone filler, and others	Not available	Rheology modifiers	Sand 1 mm	Polypropylene fibers

Gosselin et al. [2016]	XtreeE SAS®, Ecole Nationale Supérieure d'Architecture Paris-Malaquais	CEM I 52.5N Portland cement 60-67%w silica fume 16.5-20%w limestone filler 16.5-20%w	0.23	A polymer-based resin, an accelerating and thresholding agent.	Not available	No information available
Nerella et al. [2016]	Technische Universität Dresden	CEM I 52.5 R Portland cement 62%w fly ash 25%w silica fume 13%w 690 kg/ m ³	270 kg/ m ³ 0.39	Superplasticizer 1.3	Sand 2 mm 1240 kg/ m ³	No information available

- Due to the limitation of nozzle size and the demand for printing resolution, coarse aggregates are not utilized in printable concrete [Lu et al., 2016]. In Table 2, fine aggregate or sand with 2 mm maximum particle size is a common choice for most of the research institutes. Technically, without coarse aggregate (average particle size: larger than 4 mm in Europe), the 3D printable blends in Table 2 should be correctly called printable mortar. However, most of the research institutions worldwide still prefer to refer to this kind of mortar as concrete. Therefore, this paper will follow this de-facto default expression.
- In comparison with conventional concrete, a decreased water content is required in 3D printable concrete due to its required fresh properties such as low slump, and fast setting. Moreover, to develop high-strength printable concrete, it requires a lower water to binder mass ratio (w/b). For example, according to the study by Le et al. [2012a], high performance of 3D printable concrete with 110 MPa of compressive strength at 28 days is achieved by selecting a w/b of 0.26.
- Admixtures can severely influence the workability of printable concrete. For instance, adding a polycarboxylate based superplasticizer to concrete could retain w/b while enhancing its workability. A retarder formed by amino-tris, citric acid, and formaldehyde is used to keep an adequate open time and to promote a continuous flow of printing. The setting of concrete is controlled by adding an accelerator, formed by sulfate, aluminum salt, and diethanolamine [Le et al., 2012a].
- Fiber-reinforcement is also a necessary constituent in printable concrete. Polypropylene fibers are used as reinforcement by several research groups, e.g., TU Delft (publications in preparation), TU Eindhoven, and Loughborough University. Kazemian et al. [2017], Bos et al. [2016], and Le et al. [2012a] believe that adding polypropylene fibers as reinforcement could reduce shrinkage and deformation of concrete in the plastic state. Besides, glass, carbon, steel, and basalt fibers are also potential options for printable concrete [Hambach and Volkmer, 2017].

Extrudability, workability, open time, and buildability are the main characteristics of cement-based materials in the wet-process of 3DCP. Extrudability, also known as pumpability, is used to describe the property of a material that could be quickly and reliably delivered out from the transmission system. The extruded concrete should form a

continuous filament. Through visual inspection or a shear stress test of the material, the property could be determined [Lim et al., 2012, Le et al., 2012a]. Extrudability closely corresponds with the flowability and workability of concrete [Malaeb et al., 2015]. It has been proved that adding the proper amount of superplasticizer in the printing concrete facilitates a suitable workability at a low water-binder ratio [Le et al., 2012a]. Adding a retarder is to avoid the fresh concrete setting too early in the tank. On the other hand, adding an accelerator to the concrete mix allows the extruded concrete to set faster [Malaeb et al., 2015]. The open time or printability window refers to the consistent period of superior properties with a reasonable tolerance range. [Lim et al., 2012]. Le et al. [2012a] pointed out that open time should be defined as the period for extruding fresh concrete based on proper workability. In their research, open time is calculated by measuring the shear strength development of fresh concrete with time by using a shear vane apparatus.

Buildability is also defined as shape stability. It means the ability of wet concrete to resist deformation during the layer-by-layer fabrication process [Kazemian et al., 2017]. This property requires that the first layer concrete should have enough yield strength to sustain the weight from itself and subsequent higher layers. A theoretical research about rheological properties of fresh cement-based materials for 3D printing has been illustrated by Perrot et al. [2016]. For determining the buildability with fresh concrete, Kazemian et al. [2017] proposed the layer settlement and the cylinder stability tests. Besides the typical characteristics of fresh printing concrete mentioned above, the layer-to-layer adhesion which would influence the structural integrity of concrete components, is also a critical element for 3D printing concrete. The bond strength between layers should be robust enough to resist in service shearing loads [Tay et al., 2016]. Test methods for bond strength are mainly implemented in the hardened concrete stage. Le et al. [2012b], Zareyan and Khoshnevis [2017], as well as Panda et al. [2018], have performed many related tests.

3 Low CO₂ perspectives of 3D concrete printing

3D printing as an industrial manufacturing method is a possible option to reduce resource and energy consumption, and thus to decrease process-related CO₂ emissions for each unit of Gross Domestic Product [Gebler et al., 2014, Baumers et al., 2011].

3.1 *Reduced concrete consumption*

Low CO₂ aspects of printable material

Cement manufacturing is considered to be responsible for most of the environmental impact in the concrete industry because of the massive CO₂ emissions [Marinkovic, 2013]. Up to about 7% of global carbon dioxide emissions are generated by overall cement manufacturing each year. Reducing the consumption of OPC is the most efficient way to decrease CO₂ emissions. From a conventional low CO₂ concrete point of view, OPC can be partially replaced by SCMs and inert fillers. Utilizing SCMs to reduce the consumption of Portland cement is one way to promote the achievement of sustainable concrete, especially when SCMs are obtained from industrial by-products and recycled wastes [Yüksel, 2016, Meyer, 2009], like fly ash, slag, and silica fume. As shown in Table 2, SCMs (like fly ash and silica fume) and limestone are blended into printable concrete in many research groups. Kazemian et al. [2017] stated that adding silica fume in printing concrete could improve its cohesion in the fresh state, as well as the mechanical performance and impermeability when hardened. Adding ultra-fine fly ash could benefit by reducing yield strength and viscosity [Weng et al., 2016] of 3D printable concrete at the early stage. Limestone as inert filler is used to improve the workability of self-compacting concrete [Mahoutian and Shekarchi, 2015]. Blending the proper amounts of SCMs in the cementitious mix of 3D printable concrete not only aims to support adequate rheological behavior but also to reduce the consumption of OPC [Le et al., 2012a, Nerella et al., 2016]. According to the tests by Nerella et al. [2016], up to 38% of OPC is feasible to be replaced by fly ash and silica fume in the binder of 3D printable concrete. The more limestone and SCMs are added to the printable concrete mix, the more OPC will be saved. However, as shown in section 2.2, the Portland cement content in 3D printable concrete needs to be higher than for conventional concrete. This barrier to the development of low CO₂ printable concrete will be discussed in Section 4.1.

On the other hand, according to Fischer and Herr [2016], many 3DCP companies like Winsun® (China) have claimed that their printable concrete contains a significant amount of construction and demolition waste as aggregate. The demands for both natural aggregate and landfill space are thus reduced. Nevertheless, the qualities and mechanical performances of printed concrete with the required content of recycled fine aggregate are not clear in the literature. More specific studies should be implemented to determine this.

Optimized concrete structure

Lim et al. [2012] identified that the 3D model could be optimized for strength before concrete printing and thus the final print only requires the minimum amount of concrete.

According to Tay et al. [2017], topology optimization and finite element analysis can be utilized to generate optimized designs for 3DCP elements. An optimized element that is fabricated by 3DCP should consume less concrete without strength loss compared to a regularly-shaped element produced by mold casting. Combined with topology-optimized structural design methods, 3DCP becomes a more functional and sustainable fabrication method in practice. However, the printing capability of 3DCP for the optimized concrete structure is limited, which is discussed in section 4.3.

3.2 *No formwork*

Formwork currently plays an indispensable role in molding and construction processes [Martins and Sousa, 2014]. Utilizing formwork in concrete manufacturing results in high costs for material, labor, and machinery in addition to long time delays and significant negative impacts on the environment [Nerella et al., 2016]. As mentioned in the previous section, the cost of formwork is 30-60% of the total cost of a concrete structure [Perrot et al., 2016]. The cost savings of 3DCP can be understood as the savings in raw material, labor, and manufacturing energy related to the formwork. Unlike conventional concrete construction methods, the raw material can be molded directly using concrete printing without any formwork [Kothman and Faber, 2016]. The absence of formwork is the primary reason for reducing CO₂ emissions in concrete printing and can be explained as follows.

- The energy input for making molds and dealing with the wastes of formwork can be eliminated. Lower amounts of material wastes are generated during 3D printing mainly due to the absence of formwork [Perkins and Skitmore, 2015]. Finally, the CO₂ emissions related to energy consumption for formwork are thus reduced.
- Decreased labor usage in concrete construction might be a reason for CO₂ reduction. Smith [2012] pointed out that less labor could reduce the use of fuel since fewer people involved in the construction process and hence fewer vehicles are driven to and from the building site.
- In contrast to standardized concrete components with regular and highly-repetitive forms, the low CO₂ capability of 3DCP would be more significant by producing complex-shaped and customized concrete units. The reason is that conventional formwork for freeform geometries with few options for reuse by

definition needs much more energy and resource inputs. Gosselin et al. [2016] also demonstrated that manufacturing complex 3D shapes is the most attractive property of 3DCP compared with the traditional concrete casting process. Making non-standard concrete forms by conventional formwork leads to the massive generation of wastes of formwork material and frequently unexpected delays during the construction process, which would be avoided by using 3DCP with the associated low costs and decreased environmental impacts.

- At present, 3DCP also could be used to produce permanent precast concrete formwork. Steel reinforcement is still essential for large concrete structures. The precise method is to print a concrete mold, place steel rebars, and pour fresh concrete in-situ [Salet and Wolfs, 2016, Wangler et al., 2016].

4 Challenges and opportunities: developing low CO₂ 3D concrete printing

As the previous sections show, 3DCP has a significant potential to be a low CO₂ concrete production method. However, this technique is still largely under development. Many barriers impede the development of low CO₂ strategies by limiting its application in practice. In this section, low CO₂ printable concrete, safety concerns of the printed structure, as well as printing quality and capability are the major perspectives.

4.1 Low CO₂ printable concrete

Although certain amounts of common SCMs, limestone, or their mixtures are blended into printable concrete, CEM I Portland cement still accounts for 60% or more of the binder in printable concrete (Table 2). To decrease overall CO₂ footprint in 3DCP, much more Portland cement should be replaced by low CO₂ alternatives. However, many difficulties impede the development of low CO₂ printable concrete as an industrial process.

- No standard for printable concrete is currently available [Panda et al., 2017b, Panda et al., 2017c]. Conventional test methods and requirements for fresh and hardened concrete may be not applicable for 3D printable concrete. 3DCP is an emerging technique for concrete fabrication. Most of the aspects of this method are currently under development. Current research efforts are built on the experiments from only a limited number of academic institutions. Although there is no standard or guideline in effect for printable concrete, several specific test methods that are designed to replace conventional tests for concrete have been

proposed for 3DCP constructions. As mentioned in section 2.2, the shear vane test is pointed out and implemented by Le et al. [2012a] to determine the fresh properties of printable concrete, like workability and extrudability. Additionally, Kazemian et al. [2017] have conducted layer settlement tests and cylinder stability tests for exploring the buildability of fresh printable concrete. With the rapid development of 3DCP, the existing test methods will be improved, and much more predictable, processes will be designed. Standards for printable concrete will be released in the future.

- As shown in Table 2, compared with conventional concrete, a decreased amount of aggregate and increased quantities of OPC are consumed for fabricating each unit of concrete by 3DCP. Normally, an increased content of aggregate will lead to higher yield strength of the fresh concrete [Weng et al., 2016]. Increasing the content of aggregate may result in the fresh printable concrete becoming too hard to be extruded from the nozzle, as shown by Le et al. [2012a]. Thus, reducing the content of OPC by low CO₂ alternatives becomes an important method for developing low CO₂ printable concrete. However, few studies have attempted to seek an optimal mix design of low CO₂ printable concrete. Most of the printable concrete mix designs at present only consider if the concrete can satisfy the technical requirements for printing. Furthermore, replacing Portland cement by a high volume of common SCMs (fly ash, slag, and silica fume), limestone or mixtures will not be a good choice for long-term development. The world production of silica fume is about 0.5-1.0 million tons per year which is quite limited compared to other SCMs [Glavind, 2009]. According to Scrivener [2014], the total amount of available slag is only 5% of clinker, and the fly ash which is unavailable in many countries is around 30% of clinker worldwide. Therefore, it is necessary to seek new and widely available sources of SCMs. 'What alternative SCMs are available in the enormous quantities needed?' This critical question has been put forward by Scrivener [2014]. Using natural pozzolans, including volcanic ash, calcined clay, and metakaolin, as sources of SCMs may be a practical solution. Natural pozzolans are widely distributed throughout the world. The reactivity of most natural pozzolans (like volcanic ash) is quite low and variable with the geological source. However, calcined clay seems to be a better choice with high reactivity. In contrast to the temperature of 1450°C for producing clinker, it only requires 600-800°C to produce calcined clay. Moreover, the CO₂ emissions from the decarbonization of limestone ($\text{CaCO}_3 \rightarrow \text{CaO} + \text{CO}_2$) in

the clinker producing process are also decreased in the calcining process of clay. According to Huang et al. [2017], producing 1 kg of calcined clay will emit 0.2-0.37 kg of CO₂ which is significantly less than the CO₂ emissions (0.8-0.9 kg) by producing 1 kg of Portland cement [Arbi et al., 2016]. Kaolinite clay, which is the most suitable type is abundantly available in India and South-East Asia [Scrivener, 2014]. Similar arguments can be found in the study of Antoni et al. [2012]. The authors also demonstrate that mixing a proper amount of Portland cement with limestone and metakaolin can provide concrete with excellent early strength. It has been proven that replacing 45% of Portland cement by a 2:1 blend of metakaolin and limestone showed better strength than pure Portland cement at 7 and 28 days. Recently, a ternary blended cement which consists of calcined clay from low-grade kaolinitic clay, limestone, and Portland cement has received significant amounts of attention [Tironi et al., 2015]. Berriel et al. [2015] highlighted that limestone-calcined clay cement (LC3) production would have massive economic and environmental benefits. In Cuba, to compare with Portland cement, the expenses and CO₂ emissions will be reduced by using LC3 about 4-40% and 15-30% respectively, which will depend on the selected kaolinite clay deposits and the techniques of making calcined clay. Hence, it is possible to use calcined clay and limestone to partially replace OPC in printable concrete to reduce CO₂ emissions in places with shortages of fly ash, slag and silica fume.

4.2 Safety concerns of 3D printed concrete structure

Structural safety seems a significant concern for widely developing and spreading 3DCP. Whether sufficient robustness and ductility of a 3D printed structure can be obtained by a general strategy is a primary question [Bos et al., 2016]. Concrete is weak in tensile strength and ductility. Steel reinforcement is the most common way to solve this problem in conventional concrete. However, it is quite difficult to add steel reinforcement automatically and directly in the 3DCP process [Tay et al., 2017, Wangler et al., 2016]. Many alternative reinforcing methods have been introduced for 3DCP.

- As described in section 3.2, printing concrete formwork, placing steel rebars, and pouring fresh concrete currently is the most generic and applicable strategy for 3DCP to make load-bearing structural components. However, this method fails to address the fundamental problem and limits many potential advantages of 3DCP [Salet et al., 2018].

- Another possible way discussed by many researchers is to print fiber-reinforced concrete. Bos et al. [2016] illustrate that fiber-reinforced concrete with adequate tensile strength and elasticity could be developed for additive manufacturing. Hambach et al. [2016] used a 2 mm nozzle and 3-6 mm length carbon fibers to print concrete specimens for a series of tests. According to their results, a printed concrete with 3 vol.-% of carbon fibers and the fibers oriented in the stress direction has the highest ultimate flexural strength (about 120 MPa). The flexural strength of fiber-reinforced concrete is firmly dependent on the fiber orientation whether aligned in stress direction. The nozzle diameter is smaller than the average length of fibers which could contribute to proper fiber alignment. Nevertheless, the nozzle diameters or widths of current 3D concrete systems in different research groups are much larger than 2mm (see Table 1). The experiences from Hambach et al. [2016] may be not adaptable for the existing concrete printing methods. As mentioned by Bos et al. [2016], two challenges remain to impede the use of fiber reinforcement in 3DCP. First, blockage, segregation, and uneven distributions (in quantity and orientation) are not avoided even only with 1-3 vol.-% of fibers in the printable concrete. Second, how can we ensure that fibers can effectively pass through interface boundaries? Solving those problems by the current 3DCP process is considered impossible.
- The use of cable reinforcement as a more advanced concept is illustrated by Salet et al. [2018], Bos et al. [2017], and Bos et al. [2018]. At TU Eindhoven, an entrainment device that can embed various types of cables has been developed. In their first trial, significant post-crack failure strength and deformation capacity of cable-reinforced concrete have been obtained [Salet et al., 2018, Panda et al., 2017b]. However, more studies should be done. As with fiber reinforcement, cable reinforcement cannot significantly increase the layer-to-layer interface tensile strength of printed concrete.

4.3 *Printing quality and capability*

The printing quality and capability are two factors that may affect the sustainability of 3DCP. The proper mechanical performance of the printed concrete structure may also depend on the printing quality. Poor printing quality would reduce the service life of the printed concrete structure. Enhanced service life of new concrete structures also affects sustainability directly [Gjørøv, 2013]. Besides, the possibilities of printing optimized concrete structures are limited by the current printing system. As mentioned in the

previous section, fabricating an optimized concrete structure by 3DCP would reduce the consumption of OPC. Curved structures like arch, vault, and dome shapes, are a bottleneck in the aspect of printing capabilities.

- Layer effects, also known as stair casing effects, which are unavoidable in layer deposited fabrication are harmful to the quality of printed concrete components. A Low inter-layer bond strength will result in a low shear resistance of printed elements. Deformation of deposited layers and low printed surface resolution are significant barriers to printing concrete structure with small errors. Tay et al. [2017] illustrated that selecting adequately small layer thickness could improve the printing resolution. Nonetheless, a smaller layer thickness will require more time to print the same structural components. Besides layer thickness, the shape and size of nozzle seriously influence the printing resolution. The inter-layer bond strength and layer depositions are intimately connected with the time interval between placing consecutive layers. As Le et al. [2012b] reported, a longer time interval results in lower bond strength. Whereas, shorter time gaps lead to serious deformations due to the insufficient yield strength of fresh concrete. Perrot et al. [2016] propose a theoretical framework to determine the development of yield strength for the fresh cement-based printable material. As mentioned in Section 2.2, test methods for exploring the relationship between layer depositions and bond strength have been introduced by Kazemian et al. [2017] and Panda et al. [2018]. Besides the factors above, other parameters like pump speed, print path, printer head speed, layer thickness, concrete properties and nozzle standoff distance can also determine layer effects.
- As stated in section 3.1, 3DCP can be used to manufacture irregularly-shaped element directly which is an enormous advantage over conventional concrete construction. However, the advantages of 3DCP might be faded if fresh concrete is not stiff enough when it is just extruded from the nozzle. The slow setting of printable concrete strongly constrains the fabrication of topology-optimized structures, especially for printing a curved structure like an arch or dome, without supports [Tay et al., 2017, Panda et al., 2017b]. Perkins and Skitmore [2015] offered one method for 3D printing to handle those special structures by simultaneously printing another material in the void, creating a kind of scaffold. The supporting parts can be removed once they are no longer required. The

method is quite like the printing flow of Fused Deposition Modeling. Two types of materials for printing and supporting, respectively, are extruded through two nozzles separately. The support material is applied to print a support structure to avoid collapse of the printed structure. Subsequently, the support structure will be removed [Wu et al., 2016]. This idea has also been demonstrated by Duballet et al. [2017], Lim et al. [2009], and Lim et al. [2012]. Lim et al. [2009] utilized a gypsum-based material as support material, for it is low strength and can be easily removed as well as 100% recycled. More maintenance, cleaning, and control are required for operating such a supporting structure [Lim et al., 2012]. Hence, this method may not be efficient and is rarely used in concrete construction by 3D printing at present. How can we add a support structure or use an alternative way to support spanning structures during concrete printing efficiently? Exploring this in the future is worthwhile.

5 Concluding remarks

Overall, 3DCP provides new opportunities at present and in the near future. This study reports an overview of current 3DCP practices which includes the 3D printer, running system, and printable material. The constituents of 3D printable concrete used at different research institutes are quite similar, including cementitious binder, water, aggregate, admixture, and fiber-reinforcement. Additionally, potential low CO₂ strategies of 3DCP are explored. The first perspective is reduced cement consumption. In the literature, no more than 40% replacement of OPC is used by SCMs. However, to meet the requirements for printability, the content of Portland cement in 3D printable concrete is higher than in conventional concrete. Also, there is still a lack of research to explore the feasibility of using high-volume of SCMs (more than 40%) in 3D printable concrete. Moreover, using 3DCP to fabricate topology-optimized structures is also quite efficient to reduce concrete consumption without loss of robustness. Second, the absence of formwork in concrete printing could help to save large quantities of CO₂ and waste emissions related to formwork use. However, many barriers do still exist to impede the development of 3DCP, especially for its sustainable properties. The challenges and opportunities to develop low CO₂ 3DCP are discussed. Future trends of developing low CO₂ 3DCP can be summarized as follows.

- Developing low CO₂ printable concrete. In areas with abundant resources of fly ash, slag, and silica fume, it is possible to use high volumes of those SCMs as OPC replacement. In areas with a shortage of fly ash, slag, and silica fume, utilizing natural pozzolan, calcined clay and limestone from local sources to partially substitute OPC may be an alternative way to develop low CO₂ printable concrete. Besides, recycled construction wastes might be aggregate sources for printable concrete. However, more investigations and testing are still required.
- Finding suitable reinforcement methods. Safety and stability under service loads is a primary concern to impede the spreading of 3DCP in large-scale structures. There is a lack of appropriate reinforcing methods for printable concrete at present. Fiber reinforcement, cable reinforcement, and steel extrusion reinforcement are all possible developing directions.
- Improving printing quality and capability. The printing quality is weakened by layer effects that include deformations during layer deposition, low interface bond strength, and low printed surface resolution. To improve the printing quality, it requires considering the relevant printing parameters, including concrete properties, layer thickness, printing time intervals, pump speed, printing path, printing speed, and nozzle standoff distance together. On the other hand, manufacturing topology-optimized structures by 3DCP is limited by the constraints of concrete printing technology. Inspired by the Fused Deposition Modeling process, a removable supporting structure might be a solution, which is worth to be further developed.

However, this paper itself also has three limitations that need to be clarified. First, 3DCP is a new fabrication method for concrete that is still under development. The literature related to this topic is limited, and most of it was published in the past ten years. Thus, this review might not be comprehensive enough. Second, this paper focuses on exploring the potential contribution of 3DCP to sustainable, low CO₂ concrete. Nevertheless, in contrast with conventional concrete manufacturing, to what extent the carbon dioxide emissions may be reduced by using 3DCP is not explored. For example, life cycle assessments of 3DCP are required for further research. Finally, test methods to evaluate the quality of 3D printable concrete are not thoroughly presented in this paper because no standard, code or guideline is currently available. It still needs much more works for developing standard test methods.

Literature

- American Society for Testing and Materials (ASTM) (2013). ASTM F2792-10 Standard Terminology for Additive Manufacturing Technologies.
- Arbi, K., Nedeljković, M., Zuo, Y., & Ye, G. (2016). A review on the durability of alkali-activated fly ash/slag systems: advances, issues, and perspectives. *Industrial & Engineering Chemistry Research*, 55 (19), 5439-5453.
- Antoni, M., Rossen, J., Martirena, F. and Scrivener, K. (2012). Cement substitution by a combination of metakaolin and limestone. *Cement and Concrete Research*, 42(12), 1579-1589.
- Bos, F., Wolfs, R., Ahmed, Z. and Salet, T. (2016). Additive manufacturing of concrete in construction: potentials and challenges of 3D concrete printing. *Virtual and Physical Prototyping*, 11(3), 209-225.
- Buswell, R., Soar, R.C., Gibb, A. and Thorpe, T. (2007). Freeform construction: Mega-scale rapid manufacturing for construction. *Automation in Construction*, 16, 224-231
- Biernacki, J.J., Bullard, J.W., Sant, G., Brown, K., Glasser, F.P., Jones, S., Ley, T., Livingston, R., Nicoleau, L., Olek, J., Sanchez, F., Shahsavari, R., Stutzman, P.E., Sobolev, K. and Prater, T. (2017). Cements in the 21st Century: Challenges, Perspectives, and Opportunities. *Journal of the American Ceramic Society*, 100(7), 2746-2773.
- Bos, F.P., Ahmed, Z.Y., Wolfs, R.J. and Salet, T.A. (2018). 3D Printing Concrete with Reinforcement. In *High Tech Concrete: Where Technology and Engineering Meet*, 2484-2493. Springer, Cham.
- Baumers, M., Tuck, C., Wildman, R., Ashcroft, I., and Hague, R. (2011). Energy inputs to additive manufacturing: does capacity utilization matter? *EOS*, 1000(270), 30-40.
- Berriel, S.S., Díaz, Y.C., Hernández, J.F.M. and Habert, G. (2015). Assessment of Sustainability of Low Carbon Cement in Cuba. Cement Pilot Production and Prospective Case. In *Calcined Clays for Sustainable Concrete*, 189-194. Springer, Dordrecht.
- Bos, F.P., Ahmed, Z.Y., Jutinov, E.R. and Salet, T.A. (2017). Experimental Exploration of Metal Cable as Reinforcement in 3D Printed Concrete. *Materials*, 10(11), 1314.
- Dong, Y.H., Ng, S.T., Kwan, A.H. and Wu, S.K. (2015). Substituting local data for overseas life cycle inventories-a case study of concrete products in Hong Kong. *Journal of Cleaner Production*, 87, 414-422.
- Duballet, R., Baverel, O. and Dirrenberger, J. (2017). Classification of building systems for concrete 3D printing. *Automation in Construction*, 83, 247-258.

- Evans, M.A., Ian Campbell, R. (2003). A comparative evaluation of industrial design models produced using rapid prototyping and workshop-based fabrication techniques. *Rapid Prototyping Journal*, 9(5), 344-351.
- Fischer, T., Herr, C.M. (2016). Parametric Customisation of a 3D Concrete Printed Pavilion. In 21st International Conference of the Association for Computer-Aided Architectural Design Research in Asia CAADRRIA, 549-558.
- Gursel, A.P., Ostertag, C. (2017). Comparative life-cycle impact assessment of concrete manufacturing in Singapore. *The International Journal of Life Cycle Assessment*, 22(2), 237-255.
- Glavind, M. (2009). Sustainability of cement, concrete and cement replacement materials in construction. *Sustainability of Construction Materials*. Wood Head Publishing in Materials. Cambridge, UK: Great Abington, 120-47.
- Gursel, A.P., Masanet, E., Horvath, A. and Stadel, A. (2014). Life-cycle inventory analysis of concrete production: a critical review. *Cement and Concrete Composites*, 51, 38-48.
- Gosselin, C., Duballet, R., Roux, P., Gaudillière, N., Dirrenberger, J. and Morel, P. (2016). Large-scale 3D printing of ultra-high performance concrete—a new processing route for architects and builders. *Materials & Design*, 100, 102-109.
- Gebler, M., Uiterkamp, A.J.S. and Visser, C. (2014). A global sustainability perspective on 3D printing technologies. *Energy Policy*, 74, 158-167.
- Gjørsv, O. E. (2013). Durability design and quality assurance of major concrete infrastructure. *Advances in concrete construction*, 1(1), 45-63.
- Hager, I., Golonka, A. and Putanowicz, R. (2016). 3D printing of buildings and building components as the future of sustainable construction? *Procedia Engineering*, 151, 292-299.
- Hambach, M., Volkmer, D. (2017). Properties of 3D-printed fiber-reinforced Portland cement paste. *Cement and Concrete Composites*, 79, 62-70.
- Hambach, M., Möller, H., Neumann, T. and Volkmer, D. (2016). Portland cement paste with aligned carbon fibers exhibiting exceptionally high flexural strength (> 100MPa). *Cement and Concrete Research*, 89, 80-86.
- Hwang, D., Khoshnevis, B. (2004). Concrete wall fabrication by contour crafting. In 21st International Symposium on Automation and Robotics in Construction (ISARC 2004), Jeju, South Korea.
- Huang, W., Kazemi-Kamyab, H., Sun, W. and Scrivener, K. (2017). Effect of replacement of silica fume with calcined clay on the hydration and microstructural development of eco-UHPFRC. *Materials & Design*, 121, 36-46.

- Imbabi, M.S., Carrigan, C. and McKenna, S. (2012). Trends and developments in green cement and concrete technology. *International Journal of Sustainable Built Environment*, 1(2), 194-216.
- Kittusamy, N.K., Buchholz, B. (2004). Whole-body vibration and postural stress among operators of construction equipment: A literature review. *Journal of safety research*, 35(3), 255-261.
- Kazemian, A., Yuan, X., Cochran, E. and Khoshnevis, B. (2017). Cementitious materials for construction-scale 3D printing: Laboratory testing of fresh printing mixture. *Construction and Building Materials*, 145, 639-647.
- Kothman, I., Faber, N. (2016). How 3D printing technology changes the rules of the game: Insights from the construction sector. *Journal of Manufacturing Technology Management*, 27(7), 932-943.
- Lim, S., Buswell, R.A., Valentine, P.J., Piker, D., Austin, S.A. and De Kestelier, X. (2016). Modelling curved-layered printing paths for fabricating large-scale construction components. *Additive Manufacturing*, 12, 216-230.
- Lim, S., Le, T., Webster, J., Buswell, R., Austin, A., Gibb, A. and Thorpe, T. (2009). Fabricating construction components using layered manufacturing technology. In *Global Innovation in Construction Conference*. 512-520.
- Lloret, E., Shahab, A.R., Linus, M., Flatt, R.J., Gramazio, F., Kohler, M. and Langenberg, S. (2015). Complex concrete structures: Merging existing casting techniques with digital fabrication. *Computer-Aided Design*, 60, 40-49.
- Lim, S., Buswell, R.A., Le, T.T., Austin, S.A., Gibb, A.G. and Thorpe, T. (2012). Developments in construction-scale additive manufacturing processes. *Automation in Construction*, 21, 262-268.
- Le, T.T., Austin, S.A., Lim, S., Buswell, R.A., Gibb, A.G. and Thorpe, T. (2012a). Mix design and fresh properties for high-performance printing concrete. *Materials and Structures*, 45(8), 1221-1232.
- Le, T.T., Austin, S.A., Lim, S., Buswell, R. A., Law, R., Gibb, A.G. and Thorpe, T. (2012b). Hardened properties of high-performance printing concrete. *Cement and Concrete Research*, 42(3), 558-566.
- Lu, B., Tan, M.J., and Qian, S.Z. (2016). A review of 3D printable construction materials and applications. *Proceedings of the 2nd International Conference on Progress in Additive Manufacturing (Pro-AM 2016)*, 330-335.
- Meyer, C. (2009). The greening of the concrete industry. *Cement and Concrete Composites*, 31(8), 601-605.

- Mehta, P.K., Monteiro, P.J.M. (2006). *Concrete: microstructure, properties, and materials*. 3rd. ed. New York, NY: McGraw-Hill.
- Malaeb, Z., Hachem, H., Tourbah, A., Maalouf, T., Zarwin, N.E. and Hamzeh, F. (2015). 3D concrete printing: Machine and mix design. *International Journal of Civil Engineering*, 6(6), 14-22.
- Marinkovic, S.B. (2013). 3 - *Life cycle assessment (LCA) aspects of concrete. Eco-efficient concrete*, Pacheco-Torgal, F., Jalali, S., Labrincha, J., John, V.M. (ed.), Woodhead publishing, Cambridge, 45-80.
- Mahoutian, M., Shekarchi, M. (2015). Effect of inert and pozzolanic materials on flow and mechanical properties of self-compacting concrete. *Journal of Materials*, 2015.
- Martins, P.F., Sousa, J.P. (2014). Digital Fabrication Technology in Concrete Architecture. In *Fusion-Proceedings of the 32nd eCAADe Conference*, 1, 475-484.
- Nematollahi, B., Xia, M. and Sanjayan, J. (2017). Current Progress of 3D Concrete Printing Technologies. In ISARC. *Proceedings of the International Symposium on Automation and Robotics in Construction*, 34, Vilnius Gediminas Technical University, Department of Construction Economics & Property.
- Nerella, V.N., Krause, M., Näther, M. and Mechtcherine, V. (2016). Studying printability of fresh concrete for formwork free Concrete on site 3D Printing technology, (CONPrint3D). In *Proceeding for the 25th Conference on Rheology of Building Materials*, Regensburg, Germany, 2016.
- Oxman, N., Duro-Royo, J., Keating, S., Peters, B. and Tsai, E. (2014). Towards robotic swarm printing. *Architectural Design*, 84(3), 108-115.
- Proske, T., Hainer, S., Rezvani, M. and Graubner, C.A. (2013). Eco-friendly concretes with reduced water and cement contents-Mix design principles and laboratory tests. *Cement and Concrete Research*, 51, 38-46.
- Perrot, A., Rangeard, D. and Pierre, A. (2016). Structural built-up of cement-based materials used for 3D-printing extrusion techniques. *Materials and Structures*, 49(4), 1213-1220.
- Perkins, I., Skitmore, M. (2015). Three-dimensional printing in the construction industry: A review. *International Journal of Construction Management*, 15(1), 1-9.
- Paul, S.C., Tay, Y.W.D., Panda, B. and Tan, M.J. (2018). Fresh and hardened properties of 3D printable cementitious materials for building and construction. *Archives of Civil and Mechanical Engineering*, 18(1), 311-319.
- Panda, B., Lim, J.H., Mohamed, N.A.N., Paul, S.C., Tay, Y.W.D. and Tan, M.J. (2017a). Automation of robotic concrete printing using feedback control system. In ISARC.

- Proceedings of the International Symposium on Automation and Robotics in Construction*, 34, Vilnius Gediminas Technical University, Department of Construction Economics & Property.
- Pegna, J. (1997). Exploratory investigation of solid freeform construction. *Automation in construction*, 5(5), 427-437.
- Panda, B., Paul, S.C., Hui, L.J., Tay, Y.W.D. and Tan, M.J. (2017b). Additive manufacturing of geopolymer for sustainable built environment. *Journal of Cleaner Production*, 167, 281-288.
- Panda, B., Paul, S.C., Mohamed, N.A.N., Tay, Y.W.D. and Tan, M.J. (2018). Measurement of tensile bond strength of 3D printed geopolymer mortar. *Measurement*, 113, 108-116.
- Panda, B., Paul, S.C. and Tan, M.J. (2017c). Anisotropic mechanical performance of 3D printed fiber reinforced sustainable construction material. *Materials Letters*, 209, 146-149.
- Shakor, P., Sanjayan, J., Nazari, A. and Nejadi, S. (2017). Modified 3D printed powder to cement-based material and mechanical properties of cement scaffold used in 3D printing. *Construction and Building Materials*, 138, 398-409.
- Salet, T.A.M., Wolfs, R.J.M. (2016). Potentials And Challenges In 3D Concrete Printing. *Proceedings of the 2nd International Conference on Progress in Additive Manufacturing (Pro-AM 2016)*, 8-13.
- Salet, T.A., Bos, F.P., Wolfs, R.J. and Ahmed, Z.Y. (2018). 3D concrete printing—a structural engineering perspective. In *High Tech Concrete: Where Technology and Engineering Meet*, Springer, Cham.
- Smith, D. (2012). Printed buildings: an international race for the ultimate in automation. *Construction Research and Innovation*, 3(2), 26-31.
- Scrivener, K.L. (2014). Options for the future of cement. *The Indian Concrete Journal*, 88(7), 11-21.
- Tay, Y.W.D., Panda, B., Paul, S.C., Mohamed, N.A.N., Tan, M.J. and Leong, K.F. (2017). 3D printing trends in building and construction industry: a review. *Virtual and Physical Prototyping*, 1-16.
- Tay, Y.W., Panda, B., Paul, S.C., Tan, M.J., Qian, S.Z., Leong, K.F. and Chua, C.K. (2016). Processing and properties of construction materials for 3D printing. In *Materials Science Forum*, 861, 177-181. Trans Tech Publications.
- Tironi, A., Scian, A.N. and Irassar, E.F. (2015). Ternary blended cement with limestone filler and kaolinitic calcined clay. In *Calcined Clays for Sustainable Concrete*, 195-201. Springer, Dordrecht.

- Wolfs, R.J., Bos, F.P., van Strien, E.C. and Salet, T.A. (2018). A Real-Time Height Measurement and Feedback System for 3D Concrete Printing. In *High Tech Concrete: Where Technology and Engineering Meet*, 2474-2483. Springer, Cham.
- Weng, Y., Lu, B., Tan, M.J. and Qian, S. (2016). Rheology and Printability of Engineered Cementitious Composites-A Literature Review. *Proceedings of the 2nd International Conference on Progress in Additive Manufacturing (Pro- AM 2016)*, 427-432.
- Wangler, T., Lloret, E., Reiter, L., Hack, N., Gramazio, F., Kohler, M., Bernhard, M., Dillenburger, B., Buchli, J., Roussel, N. and Flatt, R. (2016). Digital concrete: opportunities and challenges. *RILEM Technical Letters*, 1, 67-75.
- Wu, P., Wang, J. and Wang, X. (2016). A critical review of the use of 3-D printing in the construction industry. *Automation in Construction*, 68, 21-31.
- Yuksel, I. (2016). A review of steel slag usage in construction industry for sustainable development. *Environment, Development and Sustainability*, 1-16.
- Zareian, B., Khoshnevis, B. (2017). Interlayer adhesion and strength of structures in Contour Crafting-Effects of aggregate size, extrusion rate, and layer thickness. *Automation in Construction*, 81, 112-121.